

characteristics :

- ◆ small area SiC-photodiode
- ◆ active aerea: 0,05 mm²
- ◆ filter option for UVC-, UVB- and UVBC-range
- ◆ more filter options on request
- ◆ hermetically sealed TO-package
- ◆ RoHS, REACH and WEEE conform

applications :

- ◆ optical measurement in UV-range with limited spectral range
- ◆ control of sterilization lamps
- ◆ flame control
- ◆ sun light measurement

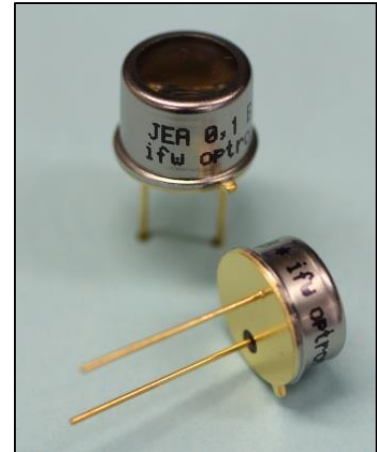

absolute maximum ratings :

- ◆ reverse voltage 10 V
- ◆ operating temperature range - 40 °C ... 125 °C
- ◆ storage temperatur range - 40 °C ... 125 °C
- ◆ soldering temperature (3s) 260 °C

technical data :

test conditions, as not otherwise specified: T_A = 25 °C , V_R = 0 V

parameter	test condition	JEA0,05C	JEA0,05BC	JEA0,05B	unit
active aerea		0,288x0,288			mm ²
spectral range					
λ _{min}	S = 0,1 * S _{max}	225	228	265	nm
λ _{max}		280	322	322	nm
wavelenght of peak response		265	275	300	nm
peak response S _{max}	S = S _{max}	0,17	0,18	0,12	A/W
dark current I _R	V _R = 1 V	10			fA
junction capacity C	f = 10 kHz	30			pF
field of view (FOV)		±45	±45	±45	Grad
weight		0,92	0,92	1,06	Gramm
height of package H		4,5	4,5	6,8	mm

relative spectral responsivity

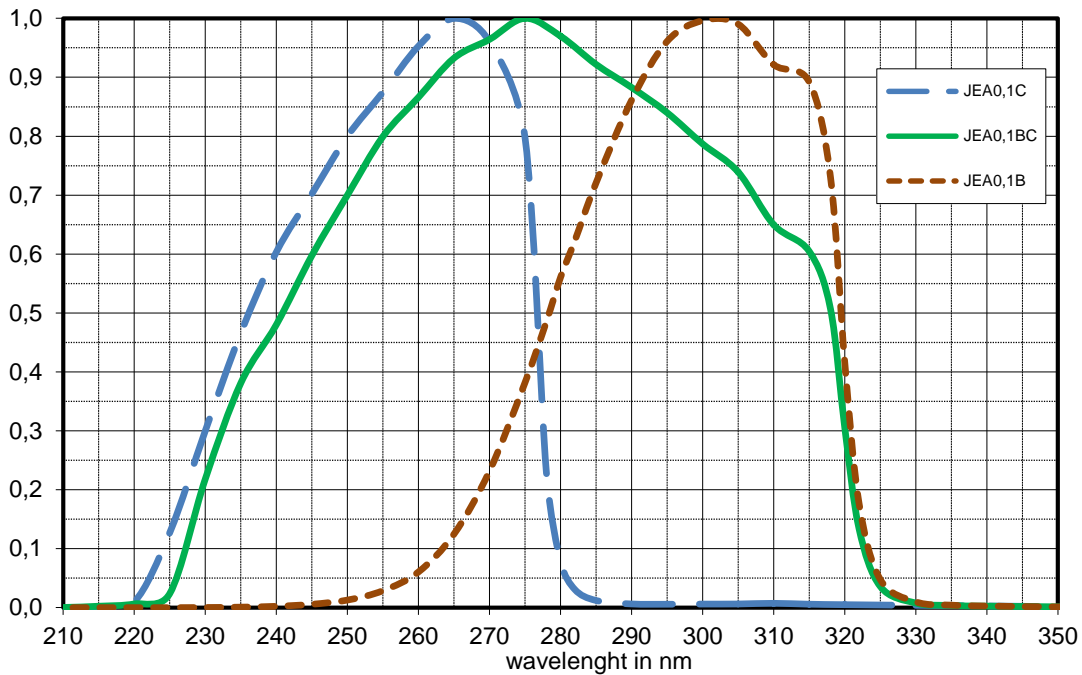

package dimension

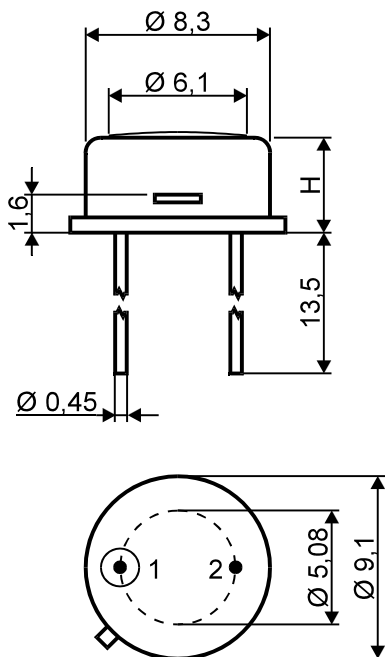

bottom view

- 1 anode
- 2 cathode & case

application example

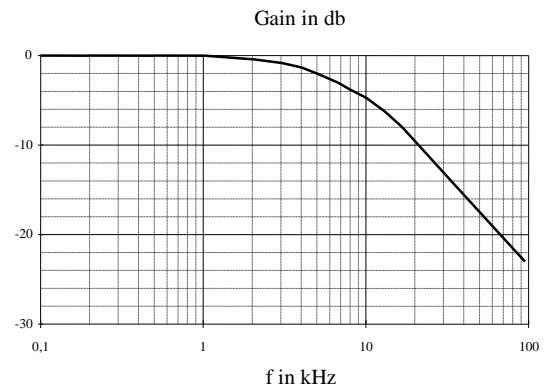
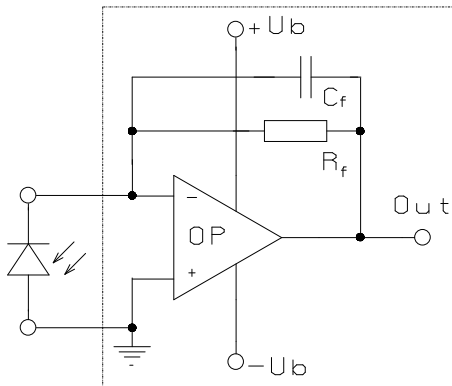

The chart shows dependence of amplitude of the application circuit with OP-amp = AD795, $R_f = 10 \text{ M}\Omega$ and $C_f = 1 \text{ pF}$

The application example shows a typical circuit R_f is responsible for the gain of the circuit. C_f compensates the reverse junction capacitance of the photodiode and the input capacitance of the OP-amp. The exact value of C_f depends on R_f , used OP-amp and capacitance of the circuit. A typical value is 1pF.

The chart shows dependence of amplitude of the application circuit with OP-amp = AD795, $R_f = 10 \text{ M}\Omega$ and $C_f = 1 \text{ pF}$